

Fire Suppression Systems

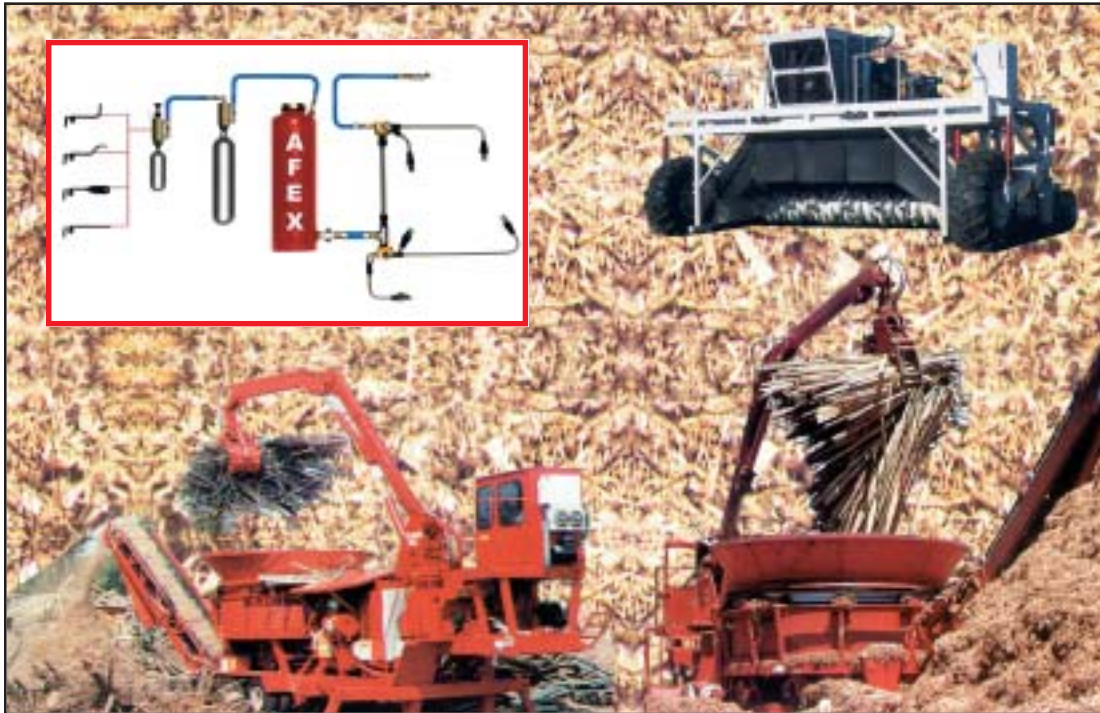

Automatic & Manual Fire Suppression Systems for The Resource Recovery Industry

Resource recovery equipment operates in an environment that has unique fire hazards. Equipment fires put capital investment and production at risk. To prevent fire losses, this equipment requires special fire protection.

AFEX fire suppression systems are purpose built for the protection of heavy equipment working in this type of environment. We are *specialists* in the manufacture of fire protection systems for heavy equipment. Our 30 years of innovation, manufacture and testing of fire suppression systems ensures that your equipment is protected with a reliable proven system.

AFEX knows heavy equipment and we design reliable systems that function and protect, but do not deter operation. AFEX systems are easily serviced and recharged in the field with common everyday hand tools, decreasing down time while protecting your valuable capital investment from fire.

No matter how hostile your equipment environment, AFEX can customize, install and guarantee a fire suppression system that works. Our distribution, service and support network is international in scope, but personalized and responsive to your specific requirements.

AFEX — *Reliable, Durable, Low Maintenance*

The Stainless Steel Tube System



The AFEX System is typically installed using stainless steel tubing in the distribution network. Once installed, the tubing is nearly maintenance free. Maintenance crews avoid time consuming hose replacements resulting from dry rot.

The tubing, unlike hose, does not tangle or intertwine among the many existing machinery hydraulic lines. It provides a clean and organized appearance that places the nozzles in fixed positions to best reach fire hazards without interfering with routine maintenance and operation of the machine.

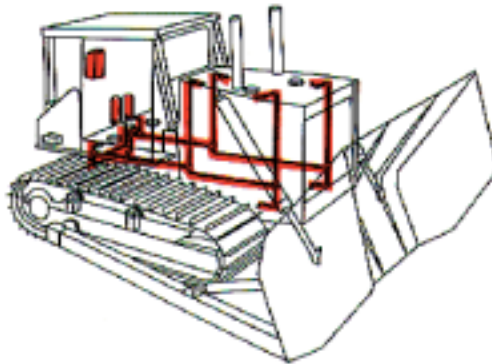

The Circuit Monitor

An option with automatic systems, the Circuit Monitor employs solid state electronics, not a microprocessor. Its functions are simple and do not require complex switching capacity. This design makes the monitor resistant to false alarms and interference from EMI, RF or potential unregulated voltage that may reach the equipment's electrical system.



The monitor uses both audible and visual alarms to alert the operator and features an operator controlled delay feature. Engine shutdown is available through the use of a pressure switch or the monitor's optional relay module. The module can also activate external alarm devices.

The monitor does not require a separate battery. Power is accessed from the equipment's battery.

The Nozzle



The AFEX Nozzle delivers a conical discharge pattern for broad distribution of the dry chemical agent, creating a "total flooding" system. The nozzle is protected by a spring-loaded hinged cap that prevents clogging and makes old style "blow-off" caps obsolete.

The Sensor

Used with automatic systems, the Sensor is manufactured to meet or exceed critical commercial and industrial specifications as well as UL and/or CSA ratings.

The sensor is a single-pole single-throw switch activated by a snap-action bimetal disc. Temperature calibrations are pre-set and each unit is 100% thermally and mechanically inspected. The case is laser welded to form a hermetically sealed housing. The sensor can be encased in various types of brackets or enclosures for mounting.

